

MODEL	FORCE [N]	POWER SUPPLY	DESCRIPTION
MVE522-65	2200	24Vac/dc	long yoke, modulating/ floating control, IP65
MVE522S-65	2200	24Vac/dc	short yoke, modulating/ floating control, IP65



APPLICATION AND USE

MVE522-65 is a flexible electro mechanical actuator for the control of two and three-way globe valves in:

- heating and cooling systems;
- Air Handling Units;
- district heating plants;
- industrial temperature control systems.

The actuator can be controlled either by a proportional (modulating) signal or by an increase/decrease (Floating) signal.

It is easy to mount and connect the actuator. Direct mounting is possible to any CONTROLLI flanged valve. Linkage kits are available for CONTROLLI threaded valves as well as for valves of other manufacturers (table p. 3). The actuator has a fine resolution (500 steps on the full stroke range) for exacting fluid control and it is able to self-calibrate on a different stroke without the need of any user action (this function is DIP switch selectable on the field).

MVE522-65 has intelligent behaviour and alarm functionality in case of unexpected operation, feedback of alarms to the user is provided by LEDs (GREEN and RED) on the control board.

N.B.: Do not use the actuator if not coupled with its relating valve.

MVE522-65 is suitable for harsh environment requiring IP65 protection degree.

OPERATION

The actuator translates the control signal (modulating or 3 point floating) from the controller into a valve position. A modern brushless DC motor in the actuator drive a gear train and a worm gear – screw jack mechanism convert the motor revolutions into accurate and repeatable linear movements.

Control Signal

MVE522-65 can be controlled by one of 2 main control types:

- 3 point floating ;
- Modulating (or proportional) signal with filed selectable range (e.g., 0-10Vdc, 2-10Vdc, 0-5/2-6Vdc, 5-10/6-10Vdc and 4-20mA).

Manual Override

There is a manual operation handle on the actuator. When it is lowered (manual override ON), the power supply to the motor power stage circuitry is cut and the motor stops. The actuator can be operated manually and the valve positioned accordingly.

The manual override lever stays in position until it is raised again, then board and motor will be powered again. At the end of this operation the actuator moves to initial position (on the basis of DIP n. 1 setting) then it follows the control signal. When the manual override is engaged the GREEN and the RED LED are ON.

Manual operation handle can also be used to modify any DIP switch setting or as re-set function after any alarm occurrence.

The actuator is supplied with the manual override lowered (ON). It is not necessary to remove power supply to modify DIP switches setting.

Position Feedback

The actuator utilizes a 2-10Vdc position feedback (look at DIP n. 1 setting).

Calibration

The actuator has both auto and manual stroke calibration, DIP n. 7. In factory delivery the auto stroke calibration is enabled – manual calibration is not necessary unless maintenance is required on the valve or certain alarm functions are desired.



End Point Auxiliary Switches (with accessory DMVE)

End point switches change over when the valve is fully open or closed. They are free contacts with 24V AC/DC, 4A max voltage on terminals. End point switches can be utilized to indicate valve stroke end positions and for relay control of additional plant equipment. When the actuators are controlled individually or in sequence, it is possible to use the end switches to toggle when the valve is fully open or fully closed. The auxiliary switch position according to control signal (Y) is shown in the picture below.

Control signal (Y)	Relay KC1	Relay KC2
0-0,5Vdc	KC1 to K2	KC2 to K3
0,5-9,5Vdc	KC1 to K1	KC2 to K3
9,5-10Vdc	KC1 to K1	KC2 to K4

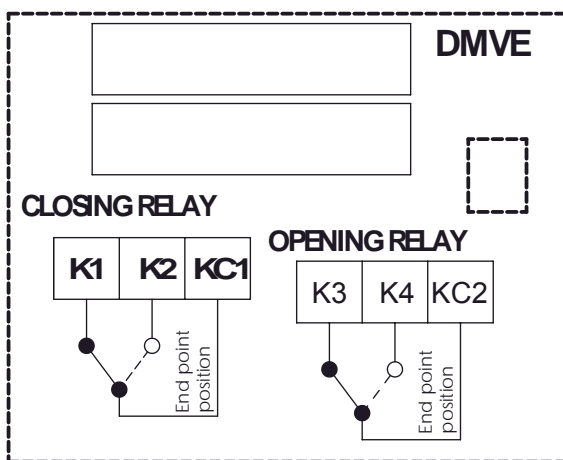

Diagnostic

The actuator is provided with a self diagnostic algorithm able to detect faulty conditions:

- stroke calibration out of range 5-60mm;
- unexpected stall condition (e.g. valve stuck or extra stroke due to actuator link loose);
- voltage supply out of range.

These faulty conditions are signalled through the GREEN and RED LED on the electronic board blinking accordingly (see Diagnostic – Alarm Function Table).

IP65

Protection against water and solid object IP65 is guaranteed by internal seals, IP65 cable gland and the proper engineering of the enclosure.

One IP65 PG13,5 cable gland and one IP65 PG13,5 plug are supplied with the actuator.

TECHNICAL FEATURES

DESCRIPTION		MVE522-65 MVE522S-65
Supply voltage L1 Ln		AC: 24Vac \pm 20% 50-60Hz DC: 22-30Vdc (Reference Ln)
Power consumption (running)		25VA / 10W
Power consumption (holding)		10VA / 4W
Running time	Modulating	60 s
	Floating	
Transformer Size [VA]		50
Stroke		5-60 mm (limited to 30 mm for MVE522S-65)
Force		2200 N
Duty cycle		max 50%/60 minutes
Analogue input Y M		voltage 0-10Vdc - impedance > 100k Ω (range: 0-10Vdc, 2-10Vdc, 0-5/2-6Vdc, 5-10/6-10Vdc) 500 Ω (range 4-20mA)
Digital inputs Y1 Y2		connection to L1 or Ln when powered in AC connection to Ln only when powered in DC
Output V+		voltage 16Vdc \pm 0,5Vdc max load 25mA,
Output U		voltage 2-10Vdc (0-100%) max load 2mA
Number of cycles of manual action		6.000
Number of cycles of automatic action		100.000
Type of action		type 1
Type of movement		linear
Room temperature		operation -10T55°C; storage -20T55°C
Room Humidity		max 90% R.H.
Protection degree		Nema 2 (*) / IP65
Insulation class		III
Printed Circuit Board		FR4 (material) PLC (Performance Level Categories) = 3 PTI (Proof Tracking Index) = 175 - 249V CTI (Comparative Tracking Index) = PTI Pollution Degree = 2
Standard		Emission/Immunity EMC 2014/30/UE according to EN 61326-1:2013 standard
Material		housing: aluminium - cover: ABS plastic
Colour		aluminium / white
Weight [kg]		1,7 (MVE522-65); 1,6 (MVE522S-65)
Date code		yy/ww

*To guarantee "Nema Type 2" protection:

- use flexible metal conduit (not supplied);
- Push the listed conduit fitting device over the actuator's cable to butt against the enclosure. Screw in conduit connector. Jack-et the actuators input wiring with listed flexible conduit. Properly terminate the conduit in a suitable junction box.

ASSEMBLING

The actuator can be mounted with any orientation but never up-side down. When the fluid temperature exceed 120°C the actuator shall be mounted leaning 45°.

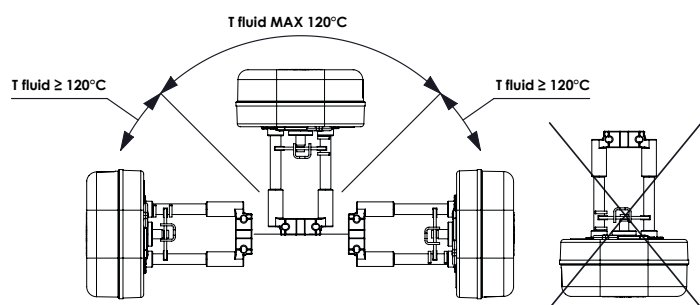

To mount the actuator on to a valve, position the valve stem to the bottom of its travel, slide the actuator onto the valve neck, adjusting with the manual override the screw jack position so the square nut on the valve spindle fits into the groove on the cross bar. Then slide the brace into the groove on the valve neck and secure the nuts.

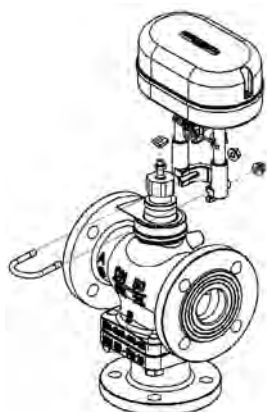

See mounting instructions for full details (MVE_DIM223).

MAINTENANCE

The actuator is free of maintenance.

ACCESSORIES

DMVE	End point auxiliary switches (electrical rate 24V AC/DC, 4A max)
248	Stem heater (suggested when the fluid temperature is below 0°C) *
GMVE	Thermal insulation for MVE actuators *
GMVE.S	Thermal insulation for MVE.S actuators *
89404-05	PG13.5 cable gland for cables with Ø variable between 6 and 12 mm

* It is not possible to install both thermal insulation (Gxxxx) and stem heaters.

Linkage	MVE522-65	MVE522S-65
Current Controlli valves (except for 2TGB.F/3TGB.F PN16)	(not required)	/
2TGB.F/3TGB.F PN16	/	(not required)
Controlli valves with threaded M40 connections (except for VSB/VMB/VSBF/VMBF PN16)	AG51	/
VSB/VMB/ VSBF/VMBF PN16	AG52	AG63
Other manufacturers		
Landis *	AG70-10 AG70-14	/
Danfoss (VR/VF (S) models)	AG60-07	/
TAC DN15-V298	AG 60-08	/
TAC DN15-V2XX/V3XX	AG 60-09	/
Honeywell **	AG 60-10	/
Airtek	AG 60-11/ AG60-12	/
Johnson Controls code VB7816-2111	AG 66	/
Johnson Controls code BM-3018-3300	AG 67	/
Tac Venta	(not required)	/
(/) this model can not be assembled		
(*) AG70-10 for valves having stem Ø 10mm AG70-14 for valves having stem Ø 14mm		
(**) valid for the following models: M6: V176A. B, V538C 1/4": V5011A		

ELECTRIC CONNECTIONS

Remove the cover screw with a screwdriver and then remove the cover as shown in the picture beside. The actuator is equipped with a 8 poles removable terminal block; the each pole of the plug is clearly marked and the same label are reported on the electronic board. Before powering up the actuator make sure the plug is properly connected to the board and the label on the plugs and on the board match.

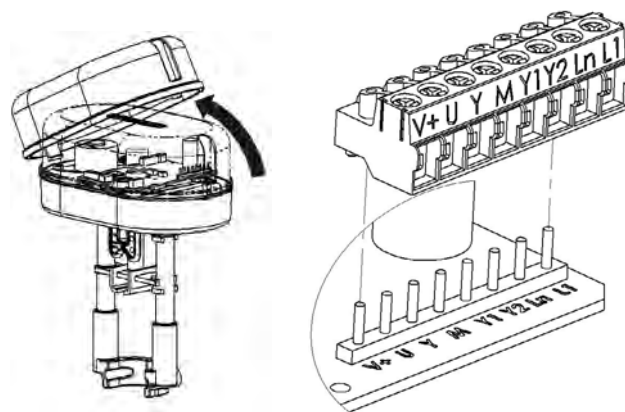

Use cable gland IP65 PG13,5 model.

TERMINAL BLOCK

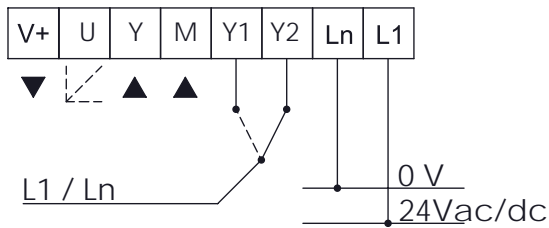

Label	Description	Function	Cable type	Max wire length
L1	24Vac/dc	Power supply	AWG 16 (min 1mm ² - max 1,5mm ²)	75m
Ln	0V			
Y	0-10Vdc	Modulating control input	AWG 20 (min 0,5mm ² - max 1,5mm ²)	200m
M	0V (common)			
Y1	Open	Floating control input	AWG 20 (min 0,5mm ² - max 1,5mm ²)	200m
Y2	Close			
V+	16Vdc	Voltage output max 25mA	AWG 20 (min 0,5mm ² - max 1,5mm ²)	200m
M	0V (common)			
U	2-10Vdc	Feedback output signal	AWG 20 (min 0,5mm ² - max 1,5mm ²)	200m
M	0V (common)			

Note: To avoid damages to electronic components caused by the PCB bending, do not press too much while fixing the terminal block.

Matching between MVE terminal block and others Controlli actuators

1	2	3	4	5	SH500
L1	L2	M	V+	Y	MVB5-MVL5-MDL5
G	G0	MX	G1	X1	MVF-MVH5-MVL5-F
L1	LN	M	V+	Y	MVE

WIRING DIAGRAMS

3-point floating control (sink connection)

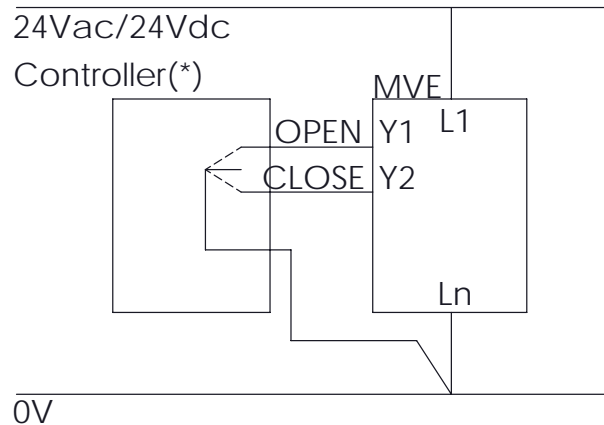

3-point floating control (source connection)

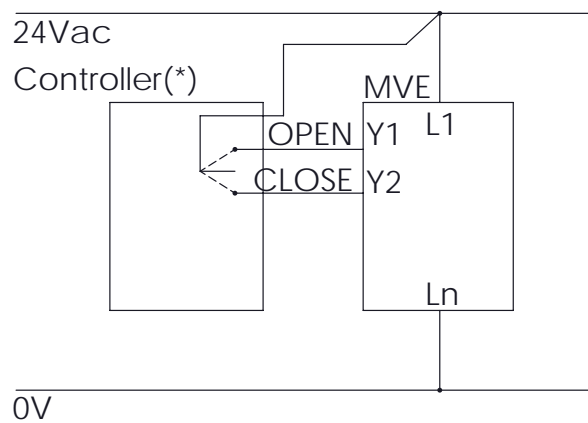

Modulating control (0-10Vcc)

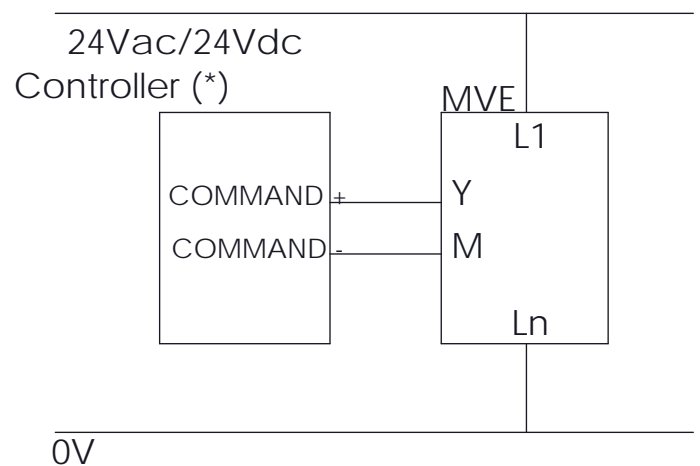

N.B.: M and Ln signals are internally connected.

(*) MVE contain a single half-wave rectifier power supply. They must not be powered with transformers that are used to power other devices using not isolated double half-wave rectifier power supply.

DIP SWITCHES SETTINGS

Set the DIP switches according to the tables here below. Power down and power up again the actuator or act on the manual override to be sure that settings will be recognized.

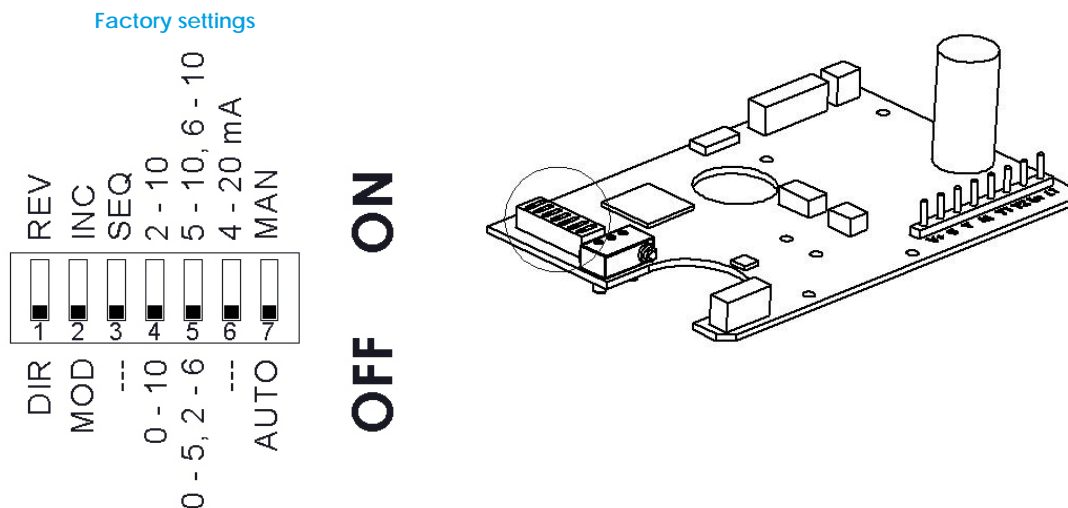

DIP switch	OFF	ON
1	<p>Direct Action</p> <p>U= feedback</p> <p>U = 2V</p> <p>U = 10V</p>	<p>Reverse Action</p> <p>U= feedback</p> <p>U = 10V</p> <p>U = 2V</p>
2	<p>Modulating Control (MOD) (Input between Y [+] and M [-])</p>	<p>3 point floating (INC) (Y1 open-extend , Y2 close-retract connected L1 or Ln if powered in Vac; if powered in Vdc connected necessarily to Ln)</p>
3	-	Selection of sequence mode, control range defined by DIP n. 5
4	Modulating Control 0-10Vdc (DIP n. 2 OFF only)	Modulating Control 2-10Vdc (DIP n. 2 OFF only)
5	Sequence Control 0-5Vdc with DIP n. 4 OFF only Sequence Control 2-6Vdc with DIP n. 4 ON only (DIP n. 3 ON only)	Sequence Control 5-10Vdc with DIP n. 4 OFF only Sequence Control 6-10Vdc with DIP n. 4 ON only (DIP n. 3 ON only)
6	Voltage Input Signal (input between Y [+] and M [-])	Current Input Signal 4-20mA (input between Y [+] and M [-]). In this case DIP n. 4 must be set to ON.
7	Automatic Calibration: the actuator updates the stroke range every time an unexpected mechanical stop is detected for at least 10s	Manual Calibration: the actuator calibration is started moving the DIP from OFF to ON or vice versa. With DIP in ON in case of extra stroke or if an unexpected endpoint is detected, the actuator will never update the stroke

DIAGNOSTIC - ALARM FUNCTIONS

N°	LEDs behaviour	Error	Actuator use	Actuator behaviour		Typical trouble shooting condition	Reset procedure
				Automatic calibration (DIP N. 7 OFF)	Manual calibration (DIP N. 7 ON)		
1	RED ON	Valve stroke less than 5mm	Calibration/ first installation	The actuator pushes/pulls 2 times (unexpected stall) trying to remove the possible obstacle. After 2 tries an alarm is signalled and the actuator moves to initial position and does not respond to control signal. Stroke value is not updated because out of range	The actuator pushes/pulls 2 times against endpoint during calibration and the actuator moves to the initial position and then it does not respond to the control signal. The actuator keeps the previous stroke	Valve with a stroke length lower than 5mm	Remove power and power up again
2	RED quick blinking + GREEN ON	Stroke longer than 60mm	Calibration/ first installation	The actuator exits the 60mm stroke range and it moves toward the new stroke limit signalling an anomaly. The actuator pushes/pulls 2 times against the new stroke limit, then it goes back to the initial position still signalling the anomaly until it is not within 60mm. The actuator does not calibrate the stroke after 10s (wrong range)	The actuator exits the 60mm stroke range and it moves toward the new stroke limit signalling an anomaly. The actuator pushes/pulls 2 times against the new stroke limit, then it goes back to the initial position still signalling the anomaly until it is not within 60mm. The actuator does not calibrate the stroke after 10s (wrong range)	Valve with a stroke length longer than 60mm	Remove power and power up again
3	RED Quick Blinking	Unexpected stall within the calibrated stroke range	normal operation	The actuator tries 5 times against the new stall condition and then after 10s the actuator updates the new stroke length	The actuator tries 5 times against the new stall condition. At the end of the attempts the fault will be signalled. The actuator does not update the new stroke length, but after 60s makes other attempts to verify the stall condition	Valve stuck	Inverted control signal
4	RED Quick Blinking	Stroke longer than expected	Normal operation	The actuator moves toward the new stall condition with a lower speed; after 10s the actuator updates the new stroke value	The actuator moves toward the new stall condition with a lower speed; after 10s the actuator does not update the new stroke value	Stem connection loose or valve damaged	Inverted control signal
5	RED slow Blinking	Low Power Voltage	Normal operation	The actuator is still working but performance cannot be guaranteed	The actuator is still working but performance cannot be guaranteed	1. Wrong transformer size 2. Unstable power	Correct Voltage Power
6	RED slow Blinking	High Power Voltage	Normal operation	The actuator is still working but performance cannot be guaranteed	The actuator is still working but performance cannot be guaranteed	1. Wrong transformer size 2. Unstable power	Correct Voltage Power

STANDARD LEDs BEHAVIOUR

N°	LED behaviour	Actuator status
1	GREEN ON	The actuator arrived at the extreme point of the stroke read
2	GREEN BLINKING	The actuator arrived at the intermediate point of the stroke read
3	RED GREEN BLINKING	The actuator is reading the stroke or it is going to initial position
4	RED GREEN ON	Manual control ON, the actuators ignores the control signal. ATTENTION! The electronic board is electrically supplied

DIMENSIONS [mm]

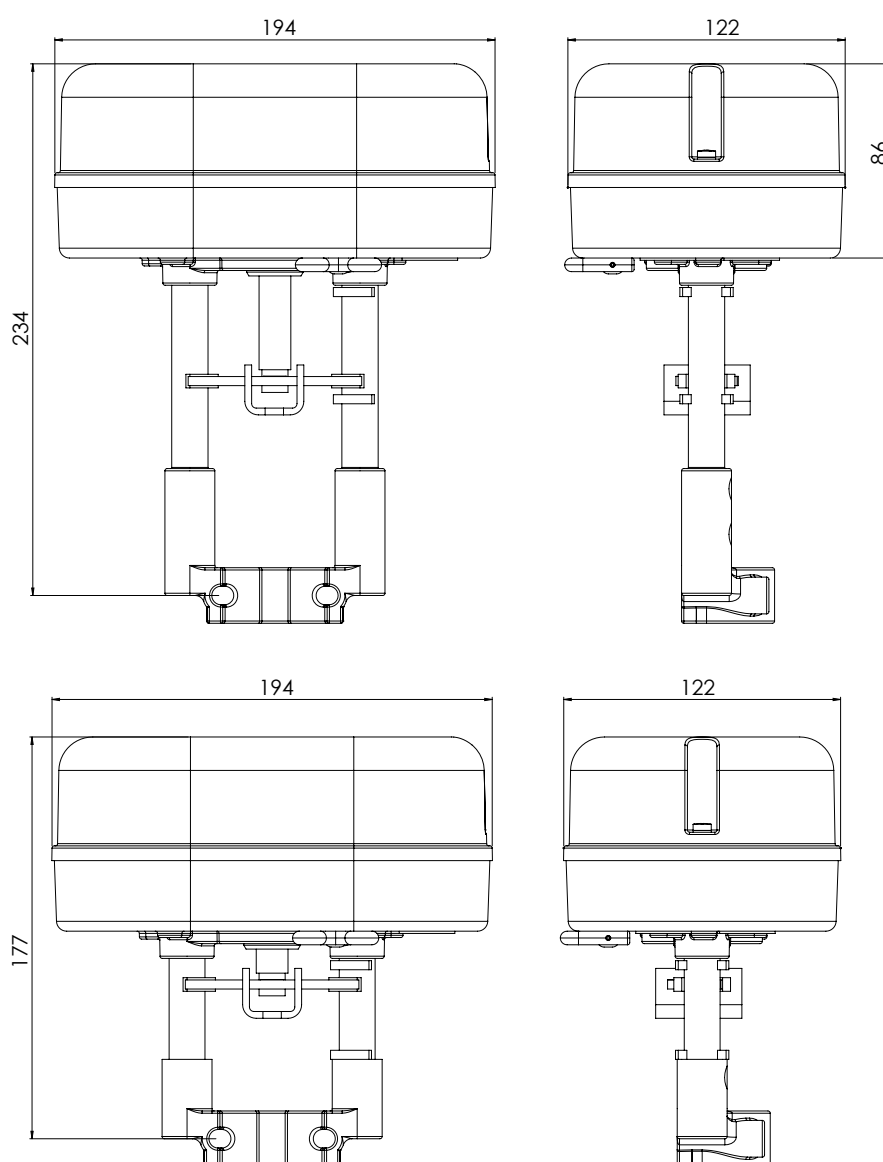

The performances stated in this sheet can be modified without any prior notice